

CITY OF WAKEFIELD
LAKESIDE CEMETERY CHARGES
ADOPTED MARCH 25, 2019

CITY OF WAKEFIELD, MICHIGAN

LAKESIDE CEMETERY

<u>GRAVE OPENING</u>	<u>RESIDENT</u>	<u>NON-RESIDENT</u>
Adults/Children over 2yrs old	\$625.00	\$850.00
Children under 2yrs old	\$325.00	\$450.00
Adults/Children on Saturday/Sunday	\$925.00	\$1150.00
Moving Bodies within the Cemetery	\$725.00	\$950.00
Burial of Cremated Remains Adults/Children	\$425.00	\$550.00
Weekend burial of Cremated Remains	\$725.00	\$850.00
Cemetery care for each burial	\$325.00	\$550.00
Cemetery Lot, per grave	\$275.00	\$475.00
Mausoleum Storage for Bodies to be interred Elsewhere	\$225.00	\$250.00
Mausoleum receiving fee (Pallbearer Assistance)	\$100.00	\$100.00

CONTACT:

DPW Foreman/Sexton: 906-229-5131
City Clerk: 906-229-5131 x 1002
FAX: 906-229-5331
Email Address: clerk@cityofwakefield.org
Website: www.cityofwakefield.org

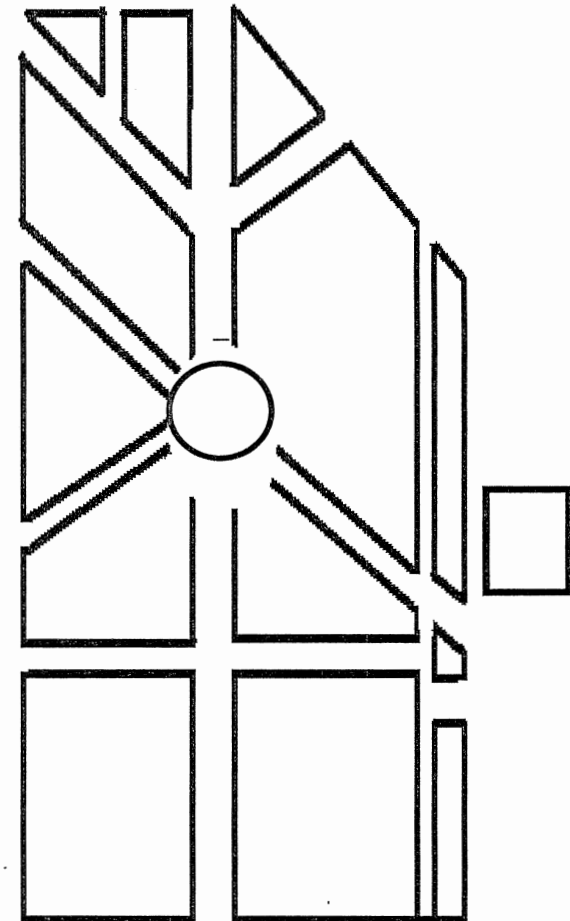

RULES & REGULATIONS

Adopted 3/25/2019

WAKEFIELD LAKESIDE CEMETERY RULES AND REGULATIONS 2019

Terms of Lot Prepayment added 7/13/15

INTRODUCTION

By establishing these rules and regulations, the City of Wakefield hopes to assure quality services in the Lakeside Cemetery and protect the interests of both the owners of Cemetery spaces and the City. All lot owners and visitors within the Cemetery shall be subject to these rules and regulations. The City reserves the right to adopt additional rules or amend, alter or repeal any rule or regulation or parts thereof at any time.

GENERAL RULES

1. Vehicles are prohibited in the Cemetery between sunset and sunrise. Vehicles must remain on established drives. The speed limit within the Cemetery is 10 MPH. Washing of vehicles within the Cemetery is prohibited.
2. Snowmobilers and all-terrain vehicles are prohibited in the Cemetery.
3. Alcoholic beverages are prohibited from being carried and consumed within the Cemetery.
4. Discharging of firearms or other explosive charges is prohibited within the Cemetery. This prohibition shall not apply to the authorized funeral volleys at burial sites or at the City Memorial.
5. No person shall permit any domestic animal to enter or remain in the Cemetery.
6. Deposition of rubbish or debris on Cemetery grounds is prohibited, except in provided receptacles.
7. No person shall pick or mutilate any flowers either wild or domestic, or disturb any tree, shrub or other plant material.
8. Because the City does not have a duly appointed Sexton, the Department of Public Works Superintendent or his appointed replacement is in charge of all Cemetery Operations.

DISINTERMENTS

1. Disinterment of a body, once properly interred, shall not be made without a properly executed disinterment permit. Graves which must be opened for inspection for any official investigation shall require an Order signed by a Court of competent jurisdiction.
2. The employees of the City of Wakefield are the only persons who will be permitted to open graves, with the following exceptions being under the direction of the Funeral Director:
 - a. When a disinterment is directed by order of a Court of competent jurisdiction and a certified copy of such order has been filed with the City.
 - b. When the medical examiner directs the disinterment for purposes of: holding an inquest and has filed with the City his signed authorization to release the body to himself or his lawful agents, the disinterment must be made by the medical examiner or his lawful agents. Cemetery employees will not be permitted to assist the medical examiner or his agents.
3. Disinterment of cremated remains shall be done only upon the authorization of the City Clerk and the next of kin (wife, husband) mother, father, or by all daughters, sons, sisters, and brothers).

ENFORCEMENT

The City of Wakefield is empowered to enforce all Rule and Regulations and to exclude from the Cemetery any persons violating the same. The City of Wakefield shall have full charge of the grounds and buildings, including the conduct of funerals, traffic, employees, plot owners and visitors.

Any person(s) shall be held fully responsible for all damages caused by said person(s)' family members or equipment and shall be fully responsible for all materials, labor and administrative costs to repair such damage, payable to the City of Wakefield.

The City of Wakefield is no liable for any injury sustained within the Cemetery.

CITY OF WAKEFIELD
Individual Marker – Maximum Size

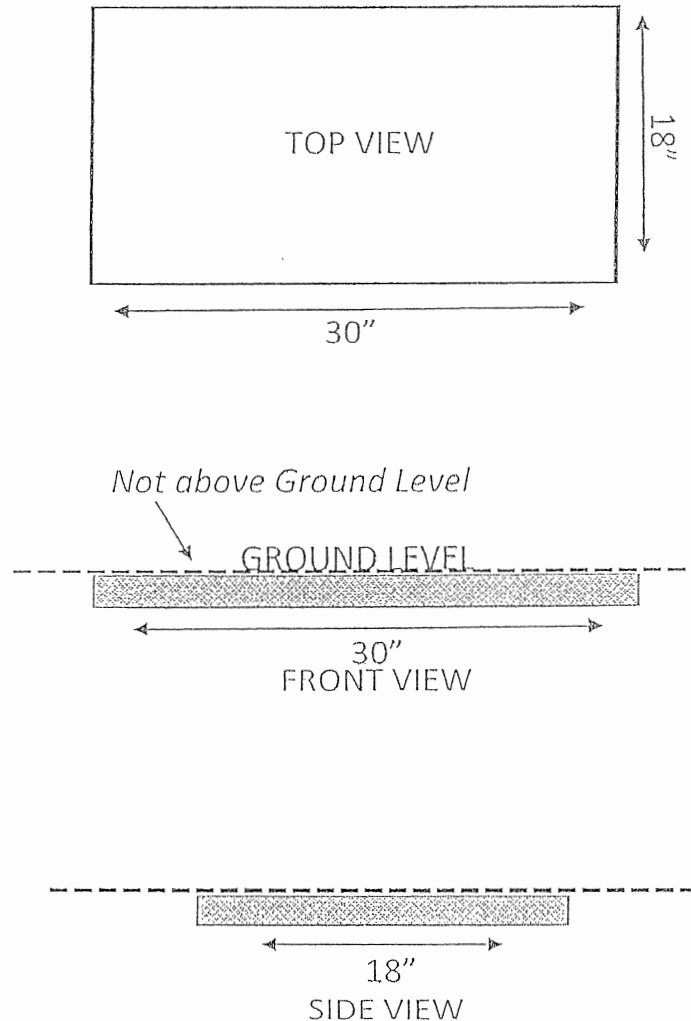

*Cemetery Sexton approval is required
prior to setting all grave markers*

CARE OF LOTS

1. Grave decorations are defined as being any objects used to adorn graves (floral offerings, statues, etc.) Grave decoration is permitted between May 1st and Labor Day. Flowers, including artificial flowers are allowed in a container (no glass jars or coffee cans).

a) Only ONE grave decoration per occupied space is permitted and must weigh no more than thirty-five (35) pounds. Any grave decoration in excess of this rule will be disposed of without notice.

b) Grave decorations, including flowers, must be removed by Labor Day. The following decorations are prohibited in the Cemetery: lights, benches, balloons and other types of shrines that would interfere with the City's Cemetery maintenance.

2. The planting of trees and the placing of wrought iron and other decorative material are all under the discretion of the DPW Superintendent. Arrangements for planting memorial trees (shade trees) and placing any wrought iron must be made with the DPW Superintendent.

3. Placing of decorated rock, wood chips, fences and other decorative material is prohibited. This must be adhered to. Decorative rock, etc. will be removed by the City crew.

4. All unauthorized planting or materials may be removed by the DPW Department.

5. The City of Wakefield shall not be responsible for floral decorations or grave markers damaged by the elements, vandals, thieves, or by other causes beyond its control.

6. Any grave decoration and/or containers deemed unsightly or hazardous will be disposed of without notice.

FUNERALS AND INTERMENTS

1. The Cemetery will be open for interments from May to October, weather and ground conditions permitting, unless other arrangements are made with the City Clerk and DPW Superintendent.

2. Notice of funerals shall be given at least eight (8) working hours in advance to the City Clerk. No interment shall take place without a Burial Permit, which shall be presented by the Funeral Director upon arrival at the Cemetery. Orders received from the Funeral Director for the opening of graves will be construed as orders from the lot owner(s).

3. The City of Wakefield will not accept direct delivery of cremated remains for burial. Receipt of cremated remains for burial must be completed through an authorized Funeral Director.

4. No more than two (2) containers of cremated remains may be buried in one grave space. No more than one (1) container of cremated remains may be buried in the graves that contain a previously interred body. Maintenance care will be charged when the grave opening is made for all grave spaces. All burial of ashes must be made by the Sexton and recorded with the City Clerk.

5. Upon entering the Cemetery, all funerals shall be under the charge of the DPW Superintendent or his appointed representation.

LOT OWNERSHIP

1. Description of all lots will be in accordance with the Cemetery Map, which is kept on file in the City Clerk's Office!
2. Sales of Cemetery lots shall be handled by the City Clerk's Office. Complete payment for the plot shall be made to the City before any burial can take place.
3. Lot sales shall be in accordance with the current rate schedule.
4. Maintenance care will be charged when the grave opening is made for all grave spaces.
5. Resident charges will apply if the deceased has maintained his/her physical residence in the City of Wakefield for thirty (30) days, or if transfer to a hospital, nursing home, or other care facility is required due to health reasons and the deceased had been a resident of Wakefield for said thirty (30) days.
6. Lots are non-transferrable.
7. All burials (except cremated remains) must be in a concrete or steel grave box or vault.
8. The City will take responsible precautions to protect lot owners and the property rights of lot owners from loss or danger, but the City disclaims all responsibility for loss or damages.
9. The deed issued by the City Clerk and a copy of these Rules and Regulations shall constitute the agreement between the City and the lot owner.
10. No lot shall be used for any other purpose than burial of the human dead.

TERMS OF LOT PREPAYMENT

1. Residents are eligible to prepay for up to two (2) spaces.
2. The difference between the prepaid rate and published rate at the time of burial must be paid in full to the Clerk before any burial can take place.
3. The Clerk is authorized to determine lot location. Any reasonable request will be accommodated.
4. Headstones, decorations or other memorabilia may not be placed on site ahead of burial. The City is not responsible for the maintenance or removal of any headstone, marker or other decoration placed prior to burial.
5. The City Council shall be the final arbiter of any dispute concerning purchases prior to burial.

CITY OF WAKEFIELD Monuments on Multiple Burial Graves – Maximum Size

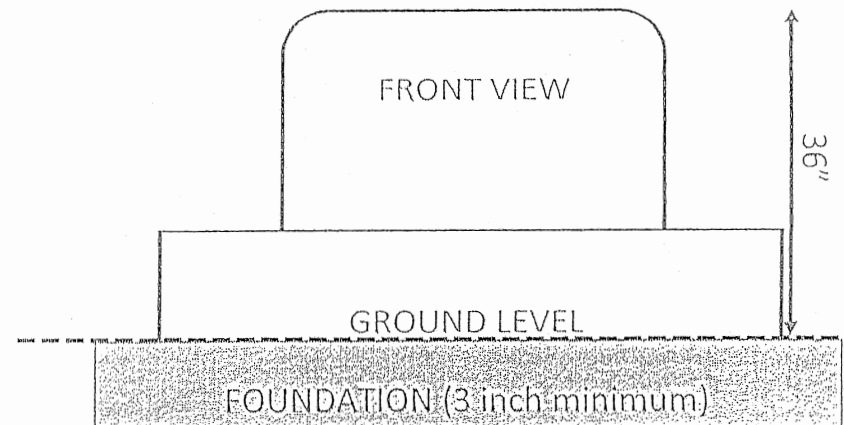
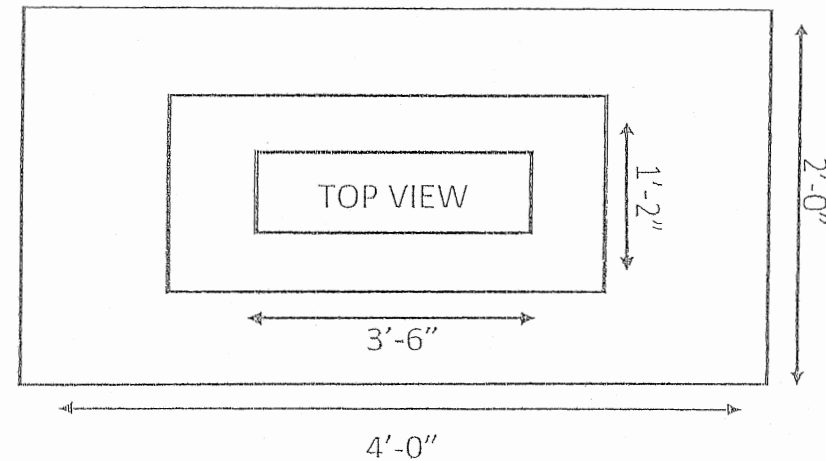

*Cemetery Sexton approval is required
prior to setting all grave markers*